

TECHNISCHE DATEN

# ROLF BENZ MIOKO

---



**ROLF  
BENZ**

- Gussfuß Metall, wahlweise: Aluminium Feinstruktur pulverbeschichtet matt:
  - RAL 9017 Verkehrsschwarz
  - RAL 7022 Umbragrau
  - Marone metallic
  - RAL 5004 Schwarzblau
  - RAL 7003 Moosgrau
  - RAL 8002 Signalbraun
  - RAL 7044 Seidengrau
  - Poliert
- Spange Stahl, wahlweise: Stahl Feinstruktur pulverbeschichtet matt:
  - RAL 9017 Verkehrsschwarz
  - RAL 7022 Umbragrau
  - Marone metallic
  - RAL 5004 Schwarzblau
  - RAL 7003 Moosgrau
  - RAL 8002 Signalbraun
  - RAL 7044 Seidengrau
  - Verchromt glänzend
- Sitzhöhen wahlweise 43 oder 46 cm

Gussfuß



Spange



- Holz-Innengestell
- Stahlwellen-Unterfederung
- Sitz aus hochwertigem Kaltschaum, abgedeckt mit einer Matte in Daunencharakter, die in Kammern gearbeitet und mit 90 % Schaumstoffstäbchen und 10 % Polyesterfasern gefüllt ist (Lounge)
- Sitz schichtweise aufgebaut mit Polyurethanschaum und einem hochwertigen Kaltschaum, in mehreren Höhen und Härten aufeinander abgestimmt, abgedeckt mit einer Polyester-Vlieshülle (Classic)
- Rückenauflage aus Polyurethanschaum
- Rückenbezug mit Polyestervlies unterstept
- Rückenkissen in Daunencharakter, in Kammern gearbeitet mit einer Füllung aus 80 % Schaumstoffstäbchen und 20 % Polyesterfasern

Lounge



Classic

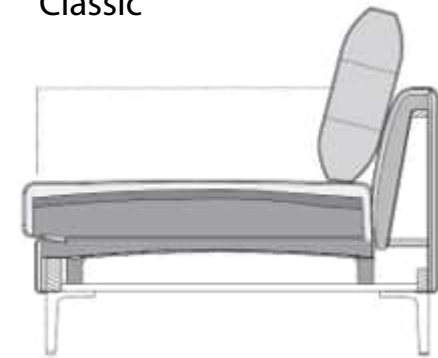

- ! Wellenbildung und Sitzspiegel sind aus Komfort- und Designgründen auch bei hochwertigen Rolf Benz Polstermöbeln nicht zu vermeiden.
- Alle Maße sind ca.-Angaben.

# Rückenkissen mit Abstand

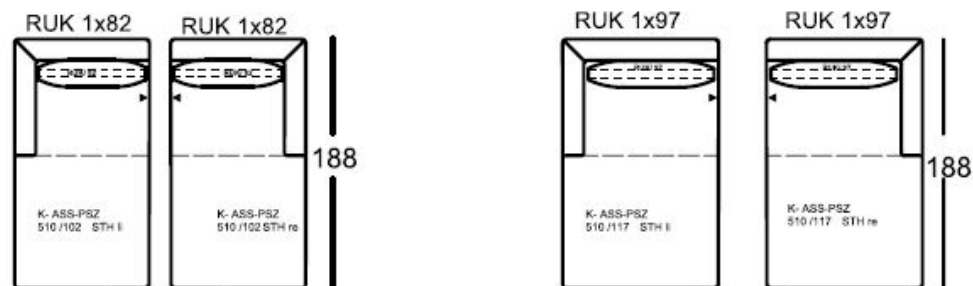
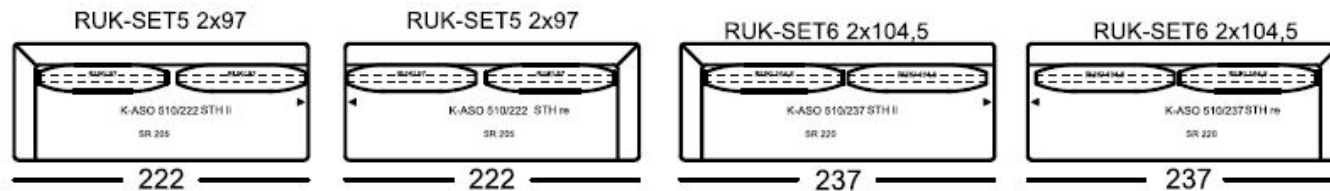
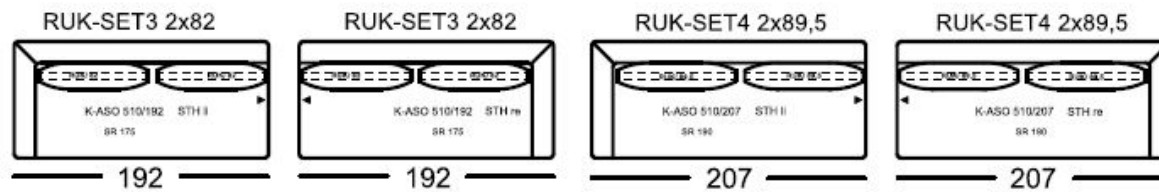
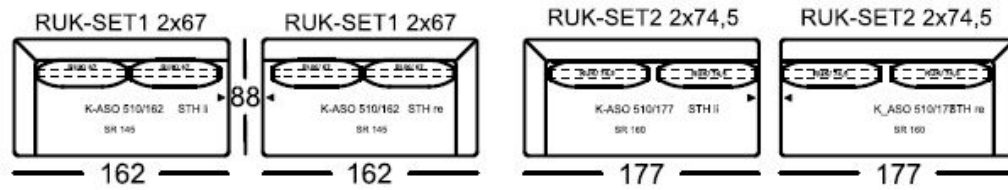
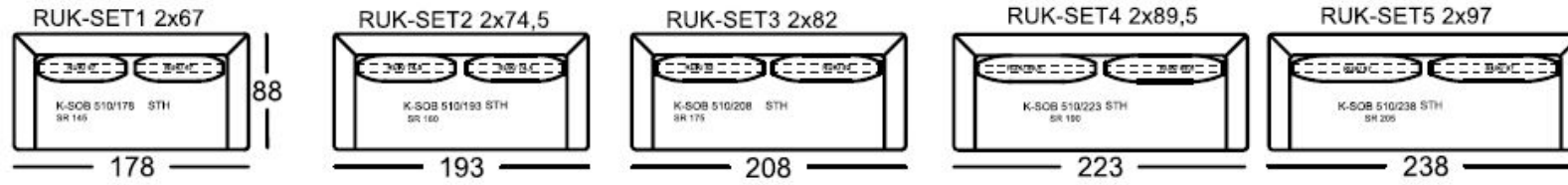

RUK-SET8 2x67 1x59,5

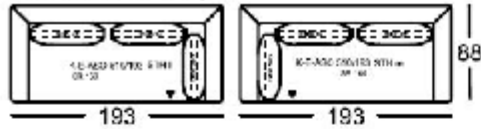

RUK-SET10 2x74,5 1x59,5

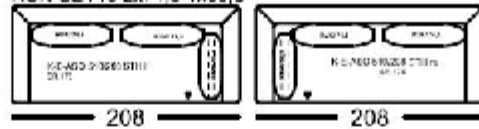

RUK-SET12 2x82 1x59,5

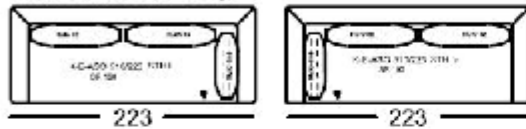

RUK-SET14 2x89,5 1x59,5

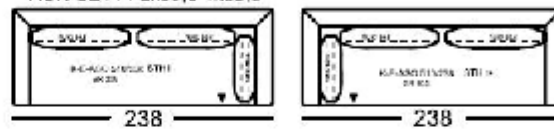

RUK-SET16 3x59,5

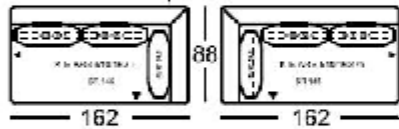

RUK-SET8 2x67 1x59,5

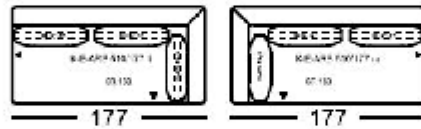

RUK-SET10 2x74,5 1x59,5

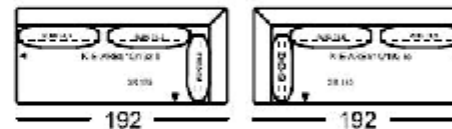

RUK-SET12 2x62 1x59,5

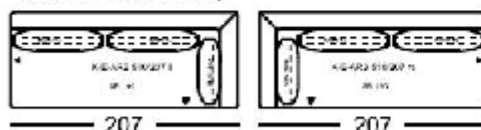

RUK-SET14 2x89,5 1x59,5

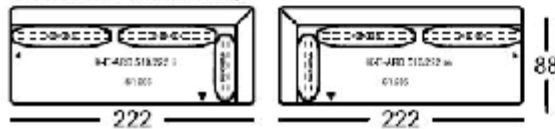

RUK-SET31 2x97 1x59,5

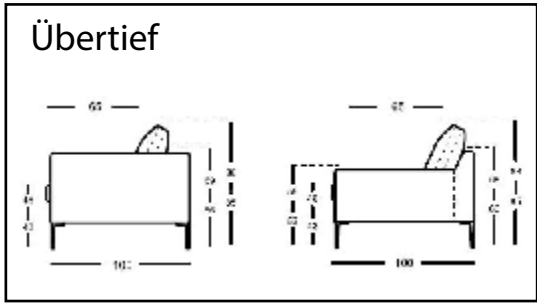
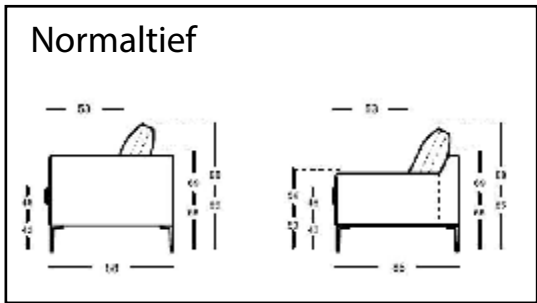
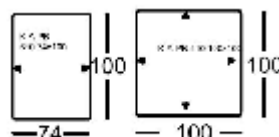
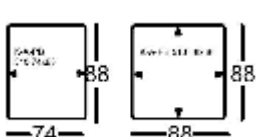
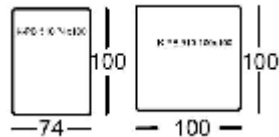
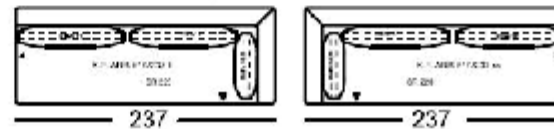

**ROLF  
BENZ**

# Rückenkissen ohne Abstand

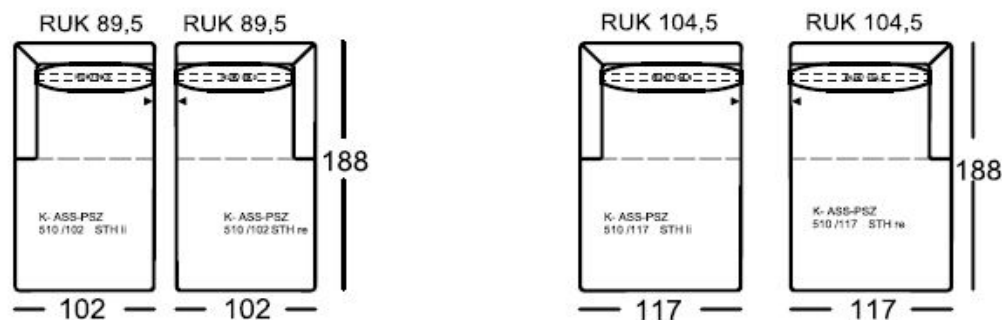
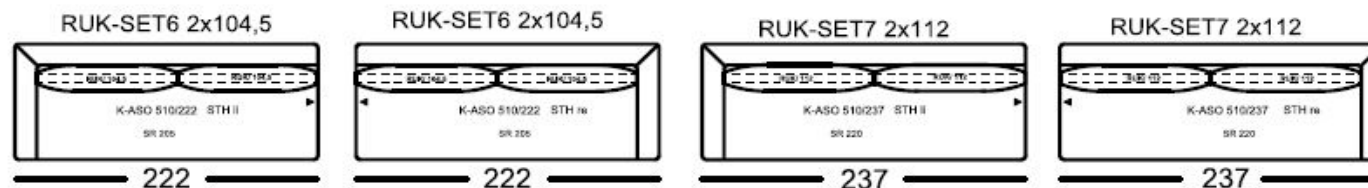
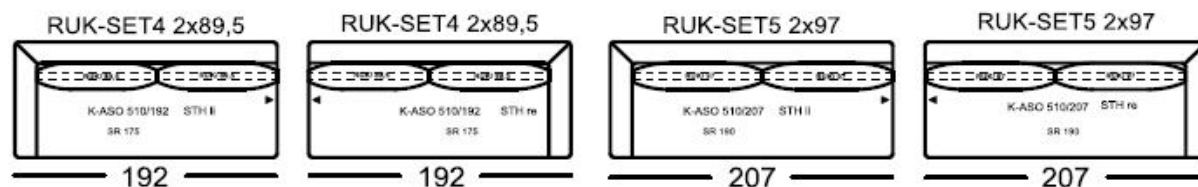
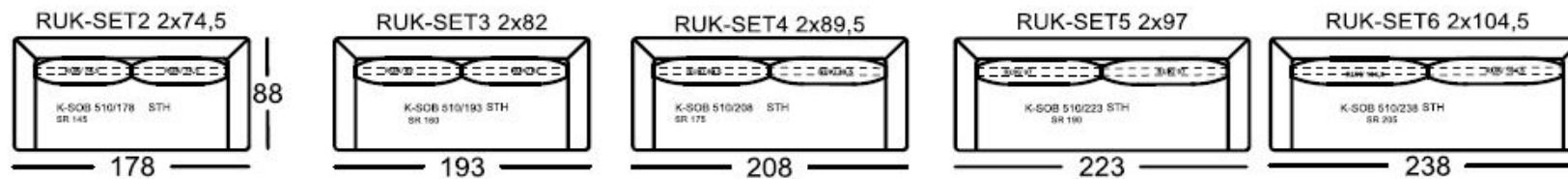

RUK-SET9 2x74,5 1x67

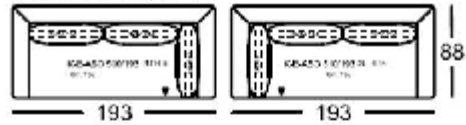

RUK-SET11 2x82 1x67

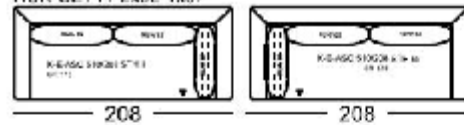

RUK-SET13 2x89,5 1x67

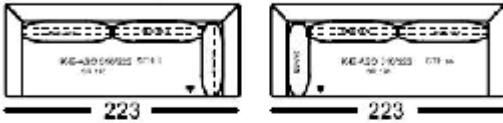

RUK-SET15 2x97 1x67

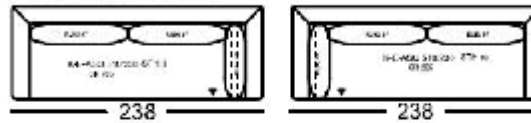

RUK-SET17 9x67

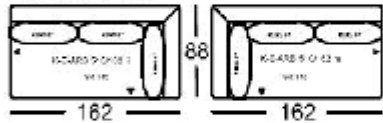

RUK-SET9 2x74 1x67

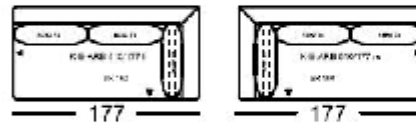

RUK-SET11 2x82 1x67

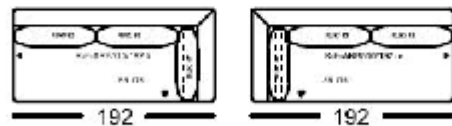

RUK-SET13 2x89,5 1x67

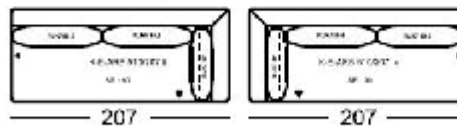

RUK-SET15 2x97 1x67

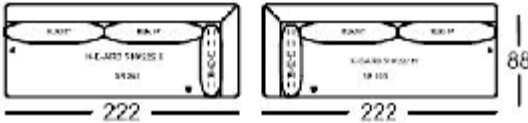

RUK-SET30 2x104,5 1x67

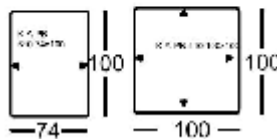
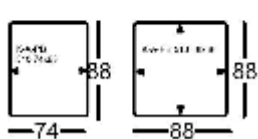
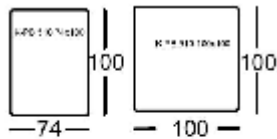
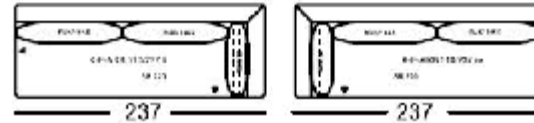

### Normaltief

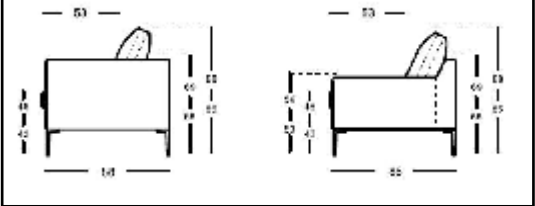

### Übertief

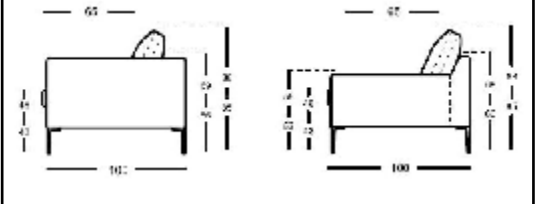

**ROLF  
BENZ**